

ItsyBitsy M4

- Power
- GND
- Control
- CircuitPython Name
- Arduino Name
- Digital
- SPI
- UART
- I2C
- PWM
- Analog

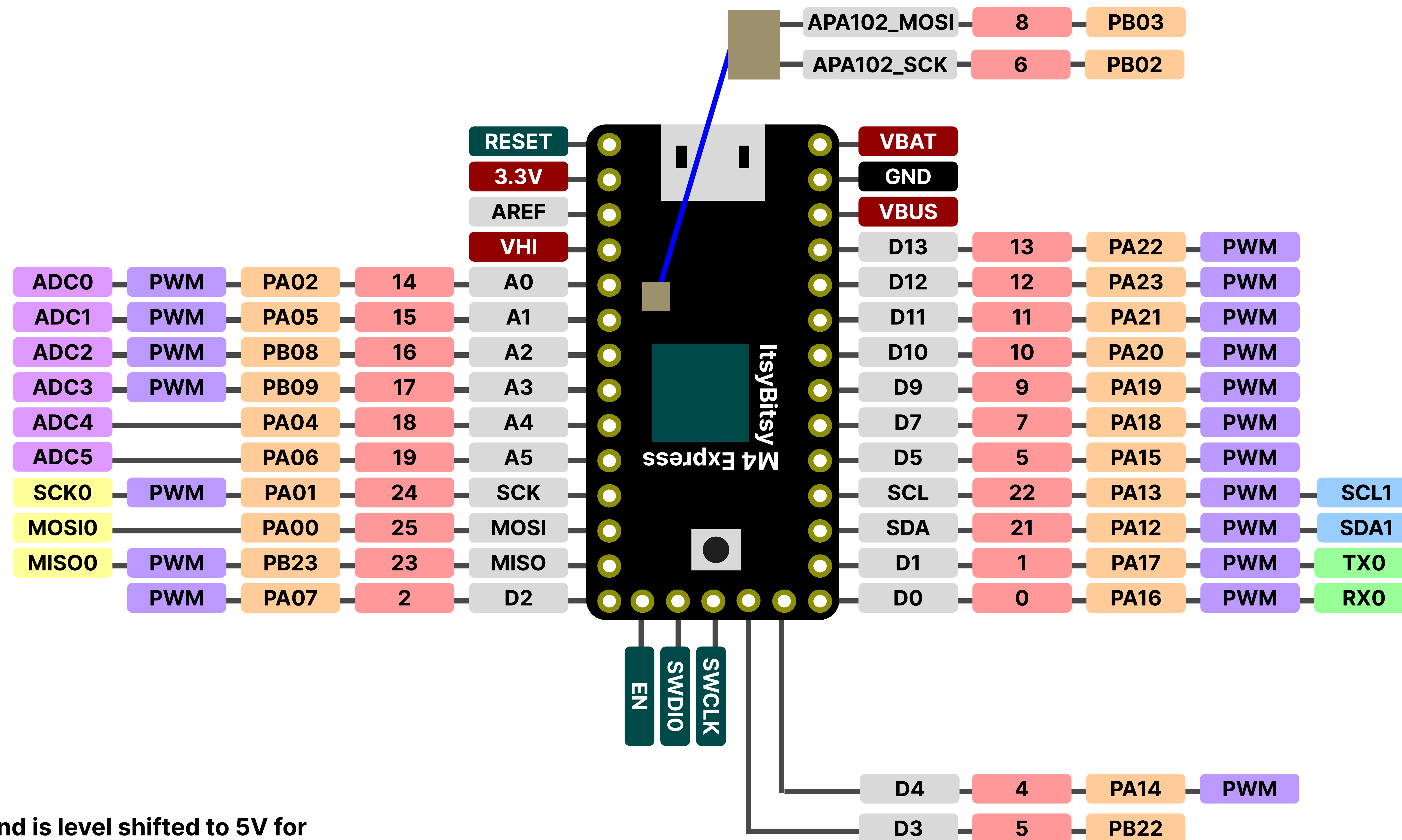

Pin D5 is an output only and is level shifted to 5V for driving Neopixels, etc.